



*Structure et la Performance de l'Agriculture
et de l'industrie des produits Agroalimentaires*

*Structure and Performance of Agriculture
and Agri-products industry Network*

Optimal quality choice under uncertainty on market development

Lota Dabio Tamini

Center for Research on the economics of the Environment, Agri-food, Transports and Energy (CREATE)

2425 de l'Agriculture St., room 4419, Paul-Comtois Bldg., Université Laval

Québec, QC, G6J 1E8

Lota.tamini@eac.ulaval.ca

Cahier de recherche/Working paper #2012-12

Optimal quality choice under uncertainty on market development

Abstract This paper analyzes the impact of risk and ambiguity aversion - *Knightian uncertainty* - on the choice of optimal quality and timing of market entry in the agri-food sector. Irreversibility of the investment in product development is introduced in a continuous-time stochastic model applying the real option literature. We consider a market characterized by a duopoly with a Stackelberg-Nash game for quality choice. When the follower provides a higher-quality good, the level of quality is decreasing in ambiguity aversion while it is a non-monotonic function of the level of risk. For low levels of risk, the increase of product quality is an efficient response. Up to certain threshold level of risk, risk and ambiguity aversion reduce the optimal quality level and increase the value of waiting when the follower supplies a higher-quality good. The implication is that risk and ambiguity aversion allow the leader to make a sustainable monopoly profit. When the follower supplies a lower-quality good, there is no value for it to wait. It should therefore provide the lowest-quality good possible. In a vertically integrated supply chain firms provide higher quality, and the difference between vertically integrated and non-integrated firms is increasing in risk and ambiguity aversion.

Key words: Quality, Duopoly, Real option, Vertical integration, Risk, Knightian uncertainty.

Résumé. Cet article analyse l'impact du risque et de l'aversion à l'ambiguïté – incertitude knightienne - sur la qualité optimale et la date d'entrée sur le marché. L'irréversibilité de l'investissement dans le développement des produits est introduite dans un modèle stochastique continu et en appliquant la littérature sur les options réelles. Nous considérons un marché caractérisé par deux firmes faisant une compétition à la Stackelberg-Nash pour la qualité. Lorsque la firme suiveuse introduit le bien de qualité élevé, celle-ci décroît avec le niveau d'aversion à l'ambiguïté alors que le choix de la qualité est une fonction non monotone du niveau de risque. Pour des niveaux faibles de risque, l'augmentation de la qualité des produits est la réponse optimale de la firme suiveuse. À partir d'un certain seuil de risque, celui-ci comme l'aversion à l'ambiguïté réduisent le niveau optimal de qualité et la firme suiveuse a intérêt à retarder son arrivée sur le marché. La firme leader se retrouve alors de manière durable dans une situation de monopole. Lorsque la firme suiveuse décide d'introduire le bien de basse qualité, elle n'a aucun intérêt à retarder son entrée sur le marché et la qualité la plus basse possible constitue la solution optimale. L'intégration verticale accroît la qualité optimale et la différence entre une firme intégrée et une firme non intégrée est croissante vis-à-vis du risque et de l'aversion à l'ambiguïté.

Mots clés: Qualité, Duopoles, Option réelle, Intégration verticale, Risque, Incertitude knightienne.

J.E.L. Classification: D81, L12, L15.

1 Introduction

Miao and Wang (2011) point out that recent economic events increase uncertainty, and firms are less sure about the evolution of key economic variables when making decisions. In the agrifood sector, risk and uncertainty about the market arise from several factors including consumers' concerns about product quality and safety, macroeconomic and agricultural policies, sanitary crises and natural disasters (Boehlje, Roucan-Kaneb and Bröring, 2011). All these shocks heighten volatility in agri-food prices, and affect industry profitability. Competition between firms, some of which are new players in global markets, has intensified concomitantly. Consequently, in the agri-food sector, as in the other sectors of the economy, firms tend to differentiate their product to relax price competition and seek some form of monopoly rent (Shaked and Sutton, 1982). Examples include high-protein hard wheat in the United States (U.S.) and Canada,¹ most of the meat supply chain,² and product differentiation and labeling in European countries.

Since the seminal works of Spence (1975) and Musa and Rosen (1978), quality choice has been analyzed extensively. Differentiation offers firms market power, naturally resolving the Bertrand paradox. In most cases, the industrial organization literature has focused on the effects of differentiation strategies on market structure, firms' performances,³ and welfare effects. However as mentioned by Asano and Shibata (2011), most of these studies do not take into account the impact of risk and uncertainty on commodity quality. Risk refers to situations in which the decision maker evaluates the likelihood of each event through a fixed probability. In some situations, however, the lack of information precludes the decision maker from attributing

¹The Neepawa variety is the varietal standard for Canada Western Red Spring (CWRS) wheat. In the U.S, the varietal development and release system is unregulated; new varieties are developed and released by both public and private firms. Variety is controlled in Canada by including varietal standards in official grade definitions and via a visual distinguishability requirement. This system enables wheat to be segregated by classes, reflecting different end-use purposes and ensures a minimum intrinsic wheat quality (see Lavoie, 2005).

²The hog marketing system in Quebec seeks to develop product differentiation by allowing specialty hogs production. A specialty hog "... is a hog that was raised and/or fed according to specific buyer demands that imply differentiation from a standard commodity hog...The specificity must be recognized by a committee that oversees differentiation in the Quebec hog/pork supply chain" (Gervais and Lambert, 2010, p. 6). Réjean Nadeau, President and CEO of Olymel, claims that Quebec pork still dominates in terms of quality, but US pork is a serious competitor. "We are still living on a reputation [of quality] that we have made over the years. That is why we must strive to keep pace maintaining this advance". See *La Terre de chez Nous*, March 28, 2012. Available at <http://www.laterre.ca/alimentation/olymel-bataille-pour-ses-parts-de-marche/> Accessed May 11, 2012.

³In a report published in 2011, Deloitte Touche Tohmatsu stated that agri-food firms are under pressure because they are operating in a sector where commodities are close substitutes. However, the major Canadian agri-food companies successfully differentiate their products to lower price competition, which explains their solid performance. See *Les Affaires.com*, April 14, 2011. Available at <http://www.lesaffaires.com/secteurs-dactivite/agroalimentaire/le-canada-champion-de-l-agroalimentaire/529648>. Accessed on May 11, 2012.

defined probabilities to events (Gilboa, 2009). This is often called Knightian uncertainty, or ambiguity.⁴ Under Knightian uncertainty (ambiguity aversion or ambiguity hereafter) the decision maker considers a set of probabilities instead of just one, as in the subjective expected utility framework.⁵ Knightian uncertainty can also be analyzed within the maxmin expected utility theory, which states that when a certain set of axioms are satisfied, the decision maker's beliefs are captured by a set of probability measures. If a firm is less confident about the future development of a market, investment will be made with caution.⁶ Rigotti and Shannon-(2005) explore the Knightian model introduced by Bewley (1989) and find no-trade conditions because of the incompleteness of preference and the related inertia assumption. De Castro and Chateauneuf (2011) also derive a Pareto optimal results and no-trade equilibrium that do not require the assumptions of constant endowments, no aggregate uncertainty and comonotonicity. The authors explain how, in the international trade context, ambiguity aversion can explain persistence in trade and the home consumption bias.⁷ De Castro and Chateauneuf (2011) also find that if the ambiguity aversion diminishes (for instance, with better knowledge of foreign markets), then trade should increase.⁸ Ghazalian's (2012) empirical results confirm the persistent magnifying effects of uncertainty aversion on home bias in the case of processed food products but not in the case of primary agricultural products.⁹

Pennings (2004) examines quality choice and entry timing when future market demand is uncertain and the quality-enhancing investment is irreversible. The author shows that risk increases optimal quality in both the monopoly case and in a Stackelberg-Nash duopoly model with a leader producing a high-quality commodity. For the monopolist, Nishimura and Ozaki (2007) and Asano and Shibata (2011) assert that the results are drastically different between risk and Knightian uncertainty. Specifically, an increase in Knightian uncertainty decreases the

⁴The importance of this distinction was made clear by Ellsberg (1961). See Asano and Shibata (2011) for a detailed description of Ellsberg's (1961) experiments and results.

⁵See Bewley (1989, 2002) for the theory behind Knightian decisions and some observations in economics that could be explained by this theory.

⁶Recent examples of empirical studies of the impact of ambiguity aversion on technology adoption are Engle-Warnick et al. (2011) and Barham et al. (2012).

⁷The home consumption bias reported in the international trade literature refers to the fact that there is less trade between countries than reasonable transportation costs would be able to explain.

⁸Kasa (2000) and Uppal and Wang (2003) suggest that uncertainty-aversion, interacting with information frictions, can create barriers to international trade. Uncertainty-averse economic agents dislike ambiguity (i.e., situations where information is less available). Huang (2007) shows that countries high in ambiguity aversion export disproportionately less to countries with which they are less familiar. The implication is that under high ambiguity aversion countries trade less and thus grow poorer in the long run.

⁹As mentioned by Ghazalian (2012: p 269) " ... primary agricultural products generally exhibit little differentiation. ... Conversely processed food products are characterized by higher levels of differentiation (e.g. intrinsic product attributes, country of production labeling). The unfamiliar attributes of foreign processed food products are expected to have higher impacts for uncertainty-avoiding consumers".

value of the investment opportunity and the optimal value of quality.¹⁰

The purpose of this paper is to analyze the impact of risk and ambiguity aversion on the choice of optimal quality and the timing of market entry in the agri-food sector. Irreversibility of the investment in product development is introduced in a continuous-time stochastic model applying the real option literature. The real option approach incorporates the value of waiting in the analyses. Because of the relatively concentrated nature of agri-food sectors,¹¹ we develop a model in which duopolists compete à la Stackelberg in choosing their quality. In doing so, we extend the work of Nishimura and Ozaki (2007) and Asano and Shibata (2011) on the impact of Knightian uncertainty and quality choice and optimal timing to enter a market. Contract farming and vertical integration play an important role in modern agriculture,¹² and may have different impacts on optimal choices. Thus, we compare the implications of Knightian uncertainty in the presence and absence of vertically integrated firms. Because in some cases we cannot derive analytical results, we rely on numerical example based on the hog supply chain in Québec, Canada.

Our results show that up to certain threshold levels, risk and ambiguity aversion reduce the optimal quality level and increase the value of waiting when the follower supplies the higher-quality good. When the follower supplies the lower-quality good, there is no gain from waiting, and the follower is better off providing the lowest-quality good possible. The implication is that under high levels of risk and under ambiguity aversion, the model predicts a sustained monopoly profit for the leader. Vertical integration reduces the follower's value of waiting and increases its optimal quality; hence both competition and welfare increase. We also show that in a vertically integrated supply chain, firms provide a higher-quality good, and the difference between vertically integrated and non-integrated firms is increasing in risk and ambiguity aversion.

The paper is organized as follows. Section 2 presents the consumer demand function and market growth, and Section 3 sets up the economic environment of the model. Section 4 presents the main results with non-integrated buyers, while contains the results with two integrated buyers are shown in Section 5. Section 6 concludes the paper.

¹⁰Barham et al. (2012) also highlights the importance of distinguishing between risk and ambiguity when studying the effect of ambiguity aversion on adoption.

¹¹See Lopez, Azzam and Liron-Espana (2002) and Stiegert, Wang and Rogers (2009).

¹²James Jr, Klein and Sykuta (2011) provide a thorough review of forms of contracting in agri-food sectors.

2 Consumer demand and market growth

Let assume that buyers face a continuum of consumers whose utility is given by Mussa and Rosen (1978) utility function:

$$U(\theta, s, p) = u_0 + \theta s - p \quad (1)$$

where the parameter s is the good quality at price p and the parameter θ is a taste parameter that varies across consumers and is assumed to be continuously and uniformly distributed over the interval $[0, 1]$. In addition, the parameter u_0 is large enough to ensure that the market is fully covered. We assume that M_t denotes the market size, i.e. the number of consumers at time t , and that it follows the geometric Brownian motion (Pennings, 2004, Chevalier-Roignant et al., 2011).

Given this assumption, the market size M is distributed according to a lognormal distribution at each instant and has independent increments; hence:

$$dM_t = \mu M_t dt + \sigma M_t dB_t \quad (2)$$

where the parameter $\mu > 0$ is the drift parameter, $\sigma > 0$ the standard deviation – the volatility of the market increase - and $B_{t|t \geq 0}$ is the standard Brownian motion. Following Nishimura and Ozaki (2007), we assume that firms are not absolutely certain about the probability of a boom and whether a particular probability is more plausible than others, which is the definition of Knightian uncertainty.¹³ In agri-food supply chains, uncertainty about the growth of the market can be explained by several factors: concerns with product quality and safety, unfamiliar attributes of processed food products, macroeconomic policies, sanitary crises and natural disasters, etc.¹⁴ Miao and Wang (2011) point out the importance of differentiating between risk and ambiguity aversion and, for Asano and Shibata (2011) “...introducing a notion of Knightian uncertainty into analyses of product development is appropriate for analyzing situations in which the change of market size in the future cannot be easily forecasted and a lot of scenarios

¹³In a discrete time setting, Nishimura and Ozaki (2007) talk about a degree of “contamination” of the confidence in probability. Chen and Epstein (2002) refer to - ignorance in the context of continuous time. Such multiple probability distributions are called Knightian uncertainty. If the firm acts in accordance with certain sensible axioms, then its behavior can be characterized as being uncertainty-averse, which increases the size of the set of subjective distributions (Bewley, 2011).

¹⁴Hofstede (1980, 2001) proposes a measure of national uncertainty-aversion. He defines an individual’s uncertainty-aversion as “feeling uncomfortable with uncertainty and ambiguity, and therefore valuing beliefs and institutions that provide certainty and conformity,” and national uncertainty aversion as the collectively held attitude of a society toward uncertainty (Huang, 2007). Using this survey and an index based on industry opacity (available information and risk level), Huang (2008) found that in high uncertainty-aversion countries, growth is slower in industries where information is less available. See, for example, Handley and Limao (2012) for a discussion about trade and investment under policy uncertainty.

can be assumed.” Within the framework of Knightian uncertainty and continuous time, the singleton set of probabilities $\{P\}$ is expanded through density generators Φ . The stochastic differential equation (2) is then (Nishimura and Ozaki, 2007):

$$dM_t = (\mu - \sigma\delta_t) M_t dt + \sigma M_t dB_t^\delta \quad (3)$$

Under the uncertainty characterized by the set of density generator Φ , the decision-maker considers the stochastic differential equation (3) with $\delta \in [-\kappa, \kappa]$.¹⁵ If $\delta = 0$, then the set of priors is reduced to a singleton, and the standard analyses under risk are appropriate. If κ increases, it means that a firm is less certain than before that the candidate’s probability measures are close to P . To avoid confusion we will refer to ambiguity aversion when talking about Knightian uncertainty.

3 Production environment

Consider an environment in which a producer supplies a differentiated good (supplier hereafter) and a buyer of that differentiated good (buyer hereafter) sells it to the consumers . Both parties are risk averse and maximize expected utility of profits net of effort costs. The supplier produces an output of quality s . Using this input, the buyer can transform and sell the output at price p .

3.1 Producers of differentiated goods

We assume that producers choose the optimal level of output q_p given the price of the differentiated product. Their expected profit is:

$$\tilde{\pi}_p(q) = R_p(q_p) - c(s)q_p \quad (4)$$

where the parameter represents the level of differentiation. We assume that the cost function $c(\cdot)$ is strictly increasing, convex, and differentiable with $c(0) = 0$ and satisfies the Inada conditions $c'(0) = 0$ and $\lim_{s \rightarrow \infty} c'(s) = \infty$ as in Acemoglu, Johnson and Mitton (2009). For simplification purpose, we assume that the average cost of production is constant with respect to the level of production. For instance let us assume that, following the literature on vertical differentiation,¹⁶ the unit cost of producing a good of quality s is:

¹⁵The set of probability measures generated is defined by $\wp^\Phi = \{Q^\delta | \delta \in \Phi\}$ where the parameter Q^δ is the probability measure continuous with respect to P and δ the density generator. For the details of the derivation of this result see Chen and Epstein (2002) and Nishimura and Ozaki (2007).

¹⁶See for example Bergès and Bouamra-Mechemache (2012).

$$c(s) = \lambda s^2 \tag{5}$$

where $\lambda > 0$. Following Kong and Kwok (2007), we allow the parameter λ to vary among the quality of the good produced. The revenue function of producers R_p is defined as:

$$R_p(q) = \omega \cdot q_p(p, s) \tag{6}$$

where the parameter ω is the per unit price received by the producer.

3.2 Product development of differentiated good

Assume that the investment in product development is assumed by the buyers of differentiated goods. In agri-food supply chains this assumption is plausible for two reasons. First because of their repeated contact with the consumers, sellers of differentiated goods have a better idea of consumers' needs related to quality and market development. For example, for simplification purpose, we assume that the average cost of production is constant with respect to the level of production.

In the Canadian meat supply chains products are developed by the packers/processors (e.g. Olymel, Coop Fédérée, Maple Leaf). In Quebec, specialty hogs are raised and/or fed according to specific buyer demands that imply differentiation from a standard commodity hog and many packers are also investigating in genetic research. Second, in most cases producers cannot carry out product development because they are too small. We assume that providing a quality of s requires a fixed development cost $I : \mathbb{R} \rightarrow \mathbb{R}$. The R&D effort and market penetration activities are two examples of fixed costs.¹⁷ The fixed cost function is represented as:

$$I(s) = \hbar s^2 \tag{7}$$

where $\hbar > 0$. The concavity of the profit function and convexity of the cost function generally allow uncertainty to condition the choice of quality.¹⁸

3.3 Structure of the game

The structure of the game follows Pennings (2004). We consider a continuous-time model where the decision on when and how much to invest in quality is endogenously determined. Let us assume that the market is characterized by a duopoly with a Stackelberg game for

¹⁷In hog production in Quebec, producing a specialty hog requires investing in some specific human and physical capital that may be of little value if offered to a different buyer. See Gervais and Lambert (2010) for discussion about opportunistic behaviors prompted by investment in specific assets.

¹⁸See Pennings (2004: pp 572-573) for the intuitions and the implications of the functional form of the investment function.

the quality choice, where the leader and follower are exogenously assigned at the start of the game.¹⁹ Stackelberg outcomes are likely when firms differ in size or technologies (Scherer, 1980; Sadanand and Sadanand, 1996). Because of the high level of concentration in food processing²⁰ this is likely to be the case. Pennings (2004) also indicates that small asymmetries in cost may not have much of an effect on equilibrium profits, but may guarantee that one firm moves first. In the Stackelberg equilibrium, the leader either offers the lower-quality good or the higher-quality good.

The timing of the game is as follows:

- In the first stage,
 - the leader decides on price (p_L^m) it charge until the follower comes into market, on quality (s_L) and on the critical market size (N_L);
 - the follower set quality (s_F) and its critical market size with $N_F > N_L$.
- In the second stage, both firm set price for the duopoly period.

Let $q_L^m = 1 - (p_L^m - u_0)/s_L$ denote the individual demand faced by the leader acting in a monopoly before the follower enters. Let q_L^d and q_F^d represent demands for the leader and the follower in the duopoly setting, respectively. Then individual demands are

$$q_L^d = 1 - \frac{(p_L^d - p_F^d)}{(s_L - s_F)} \quad \text{and} \quad q_F^d = \frac{(p_L^d - p_F^d)}{(s_L - s_F)} \quad \text{if } s_L > s_F \quad (8)$$

$$q_L^d = \frac{(p_F^d - p_L^d)}{(s_F - s_L)} \quad \text{and} \quad q_L^d = 1 - \frac{(p_F^d - p_L^d)}{(s_F - s_L)} \quad \text{if } s_L < s_F \quad (9)$$

Under the assumptions that the planning horizon is infinite and in the presence of risk and ambiguity aversion represented by the parameter κ , the expected profit function of the leader is (Pennings, 2004; Asano and Shibata, 2011):

$$\pi_L = \frac{N_F (p_L^d - \omega - c) q_L^d}{r - (\mu - \sigma\kappa)} \left(\frac{M}{N_F}\right)^\alpha + \frac{N_L (p_L^d - \omega - c) q_L^m}{r - (\mu - \sigma\kappa)} \left[\left(\frac{M}{N_L}\right)^\alpha - \left(\frac{M}{N_F}\right)^\alpha \right] - I(s) \left(\frac{M}{N_L}\right)^\alpha \quad (10)$$

where the parameter ω , defined above, represents the cost of acquiring the good, the parameter c represents the marketing cost and the function I stands for the irreversible investment

¹⁹Other examples of duopoly models of strategic investment under uncertainty are Weeds (2002) and Kong and Kwok (2007).

²⁰See for example James, Hendrickson and Howard (2012, Table 1).

in quality development defined above. From equation (10) it is clear that the leader takes into account the fact that, given the follower's action, could act as a monopolist. The follower's expected profit is:

$$\pi_F = \left[\frac{N_F (p_F^d - \omega - c) q_F^d}{r - (\mu - \sigma\kappa)} - I(s) \right] \left(\frac{M}{N_F} \right)^\alpha \quad (11)$$

Following the literature of strategic investment under uncertainty,²¹ we assume that the firm chooses quality and critical market size to maximize expected profits. Dixit and Pindyck (1994) and Nishimura and Ozaki (2007) show that the first order condition for the critical market size at which to invest is characterized by:

$$\pi \hat{N} = \frac{\alpha}{\alpha - 1} I(s) \quad (12)$$

while the conditions regarding the level of quality is:

$$\pi_S N = I_S \quad (13)$$

where,

$$\alpha \equiv \frac{-\{(\mu - \sigma\kappa) - \frac{1}{2}\sigma^2\} + \sqrt{\{(\mu - \sigma\kappa) - \frac{1}{2}\sigma^2\} + 2r\sigma^2}}{\sigma^2} \quad (14)$$

The parameter r is the discount rate with $r > 0$ and $r > \mu - \sigma\kappa$; the other parameters are as defined before. Following the investment literature it is established that $\alpha > 1$ (Pennings 2004, p. 572; Dixit and Pindyck 1994, p 142). Equations (12) and (13) imply that the firm invests only if the profitability level exceeds the return on its investment. Equation (12) captures the value of postponing the quality-enhancing investment, and thus captures the option value.

3.4 Structure of the economy

Given that some of the interrelations of the main parameters are complex, we follow Bergemann and Välimäki (2002), Pawlina and Kort (2010) and Wang (2010) when referring to numerical examples to illustrate the analyses. The economic environment mimics the hog supply chain in Québec. We use data on per capita consumption of pork for the values of the drift parameter and the standard deviation. Over the past 40 years, the mean increase in per capita pork consumption in Canada was 5.14%, with a standard deviation of 0.096. When considering the

²¹For a thorough review of the literature on strategic investment under uncertainty see Chevalier-Roignant et al. (2011).

past 10 years the increase was 0.07% (standard error of 0.08).²² We then set the drift parameter at $\mu = 0.05$ and use a value of standard deviation of $\sigma = 0.1$ as a base value of volatility of market development. Without loss of generality, and following Gervais and Lambert (2010) we set $c = \$25$. In 2010, hog production in Québec was 7.7 million heads, sales was amounted to \$1.2 trillion (MAPAQ, 2010). About half of the production was for export markets with the USA, Japan and European Union as the main destinations. In addition, as mentioned before, the hog marketing system in Quebec seeks to develop product differentiation by allowing specialty hog production. Even if the development of specialty hogs is ongoing, we assumed that about half of the total demand concerns specialty hogs. The market size of the economy (M) is thus set to 3.5 million heads. Given these data, the investment parameter \hbar was calibrated to have a value of $1.25 \cdot 10^6$. Finally, we consider a discount rate $r = 0.1$.

4 Optimal quality with two non-integrated buyers

Let us assume a context with a marketing mechanism that rests on two important components: product quality (s) and the price paid to producers (ω). We assume that the buyer makes an offer to producers (ω, s) , which implies that producers will deliver an input of quality s and receive a price ω . We also assume producers receive zero payment if they do not abide by the terms of the contract. This marketing mechanism is consistent with Québec marketing in the hog supply chain. As described in Gervais and Lambert (2010), when a specialty hog is officially recognized by the differentiation control committee, the buyers offer producers a premium and suggest mechanisms to adjust it to fluctuations in the production cost. From equations (4)-(6) it is easy to derive that the buyer offers a price ω equal to the marginal cost of production of the quality that is $\omega = 2\lambda s$; this will lead to zero profit for producers.²³

4.1 Stackelberg-Nash game with the follower supplying lower-quality good

As usual, the game is solved using backward induction. We determine optimal prices first. To ensure that the contract is upheld, buyers set the price to be equal to marginal cost. We assume that buyers decide on margin $\varpi_L \equiv p_L - \omega_L$ and $\varpi_F \equiv p_F - \omega_F$. The two firms' profits are:

$$\pi_L = \left(\frac{M}{N_L} \right)^\alpha \left[\frac{(\varpi_L - c) q_L}{r - (\mu - \sigma \kappa)} M - I(s_L) \right] \quad (15)$$

²²In the past 40 years, the mean increase in per capita consumption of beef in Canada was 5.64% with a standard deviation of 0.24. In the past 10 years, the corresponding increase was 0.018% (standard error of 0.17).

²³As mentioned before, this is the equilibrium where the contract is upheld. Examples of contractual forms with the possibility of contacts that are not upheld can be found in Acemoglu, Johnson and Mitton (2009).

$$\pi_F = \left(\frac{M}{N_F} \right)^\alpha \left[\frac{(\varpi_F - c) q_F}{r - (\mu - \sigma\kappa)} M - I(s_F) \right] \quad (16)$$

When the leader provides the higher-quality good, we use the demand functions defined by equation (8) to solve for the reaction functions of the two players.

The Nash equilibrium margin functions of the leader and the follower are:

$$\widehat{\varpi}_L = c + \frac{2}{3}(s_L - s_F) \quad (17)$$

$$\widehat{\varpi}_F = c + \frac{1}{3}(s_L - s_F) \quad (18)$$

Follower's optimal choices Substituting equilibrium margin (18) and the demand functions defined by (8) in the profit function given by equation (16), the follower's profit is:

$$\pi_F = \left(\frac{M}{N_F} \right)^\alpha \left[\frac{N_F(s_F - s_L)}{9(r - (\mu - \sigma\kappa))} - I(s_F) \right] \quad (19)$$

The result of the profit maximization with respect to quality is that the follower chooses the lowest quality possible:

$$\widehat{s}_F = \underline{s} = 0 \quad (20)$$

Given its choice of quality, the partial derivative of the follower's profit function with respect to the threshold market size is negative. The follower enters the market as early as possible.²⁴

Leader's optimal choices By substituting the follower's optimal choice in the leader's expected profit function, the leader's choice of quality as a function of optimal market size is:

$$s_L = \frac{2N_L}{9h(r - (\mu - \sigma\kappa))} \quad (21)$$

Substituting the optimal quality (21) in the leader's profit function (15) and deriving it with respect to threshold market size gives a negative solution. The leader then invests immediately, and because the outcome reduces to a static game, the leader's optimal quality is:

$$\widehat{s}_L = \frac{2M}{9\hbar(r - (\mu - \sigma\kappa))} \quad (22)$$

Under Pennings' (2004) result without ambiguity aversion, the optimal level of product quality is not a function of risk and uncertainty. In the setting at hand, an increase in both the

²⁴See Pennings (2004) for the details.

risk ($\sigma \uparrow$) and in the ambiguity aversion ($\kappa \uparrow$) induces a decrease in the optimal choice of quality. The latter's impact is also found by Asamo and Shibata (2011) in a monopolistic setting. The findings of this section are summarized by proposition 1. The first part of proposition 1 is the result found by Pennings (2004).

Proposition 1 *Under the Stackelberg-Nash game, when the follower provides the lower-quality good, there is no value in waiting to invest in quality for either the leader or the follower. They both enter the market immediately (Pennings, 2004). The follower chooses the lowest quality possible, and an increase in both the ambiguity aversion ($\kappa \uparrow$) and the risk ($\sigma \uparrow$) induces a decrease in the leader's optimal quality level, along with a decrease in optimal prices.*

Proof. The first part of proposition 1 summarizes the finding of the preceding section about the leader and follower's optimal choices. Therefore, the proof is omitted. From equations (17), (18) and (22), $\partial\varpi/\partial\sigma = (\partial\varpi/\partial s_L)(\partial s_L/\partial\sigma) < 0$ and $\partial\varpi/\partial\kappa = (\partial\varpi/\partial s_L)(\partial s_L/\partial\kappa) < 0$. ■

The intuition of these results is that because the leader is less optimistic about the future development of the market size and about its expected profits, it provides the product at a lower quality and price. Increases in risk and ambiguity aversion enhance the option value of the investment in quality. The implication is that an increase in risk and ambiguity aversion lowers demand per consumer following the decrease in the quality of the leader's product (see equation (8)). These results are close to some in the literature on labeling with imperfect regulation (e.g. Sheldon and Roe, 2009) and on the value of commitment when information is noisy (e.g. Maggi, 1999). In these cases, there is underprovision of quality. The results under ambiguity aversion contrast with those of the Stackelberg-Nash game of Pennings (2004), in which an increase in risk has no impact on the optimal level of quality when the leader chooses higher quality. The result of Pennings (2004) confirms that the ambiguity aversion coefficient is absent from the market size increment. Figure 1 represents quality choices by the leader as a function of risk and ambiguity aversion.

Considering that the two firms enter the market immediately, and inserting the leader's optimal quality choice (equation (22)) in equations (15) and (16) we get the equilibrium profits of the two firms as:

$$\pi_F = \left[\frac{2M}{9\bar{h}(r - (\mu - \sigma\kappa))\bar{h}} \right]^2 \frac{\bar{h}}{2} \quad (23)$$

$$\pi_L = \left[\frac{2M}{9\bar{h}(r - (\mu - \sigma\kappa))\bar{h}} \right]^2 \bar{h} \quad (24)$$

The leader's profit is always higher than the follower's one which is a classical result in the Stakelberg-Nash game setting. Figures 2a and 2b represent the profits of the two firms as a

function of the risk and ambiguity aversion. The two figures show that the difference in profits between the two firms vanishes with an increase in ambiguity aversion and risk because of low level of quality differentiation. In Pennings' (2004) setting, there is no κ -ignorance and risk has no impact on the choice of the leader's quality and the difference between the two profits is constant.

4.2 Stackelberg-Nash game with the follower supplying higher-quality good

Let us now assume that the follower supplies the higher-quality good. The demand functions are given by equations (9), and, using equation (16), the follower's expected profit is:

$$\pi_F = \left(\frac{M}{N_F}\right)^\alpha \left[\frac{4N_F(s_F - s_L)}{9(r - (\mu - \sigma\kappa))} - I(s_F) \right] \quad (25)$$

The follower's profit maximization behavior with respect to the market size threshold and the quality of good allows us to derive the optimal quality and market size threshold given the leader's level of quality. The market size threshold is:

$$\hat{N}_F = \frac{9(r - (\mu - \sigma\kappa))(\alpha - 1)}{\alpha - 2} \bar{h}_{s_L} \quad (26)$$

Proposition 2 *When the follower introduces a higher-quality good, delaying entry is profitable for the follower. Given the leader's choice of quality, the impact on the threshold market size is an ambiguous function of the value of the risk (σ) and that of ambiguity aversion (κ).*

Proof. The sign of the impact of an increase in risk on the threshold market size under

κ -ignorance is $sign(\partial\hat{N}_F/\partial\sigma) = sign\left[\underbrace{\left(\frac{\partial\hat{N}_F}{\partial\alpha}\right)}_{< 0} \underbrace{\left(\frac{\partial\alpha}{\partial\sigma}\right)}_{\leq 0} + \underbrace{\left(\frac{\partial\hat{N}_F}{\partial\sigma}\right)}_{> 0}\right]$ and is undetermined. The qualitative impact of an increase in ambiguity aversion is determined by

$$sign\left(\frac{\partial\hat{N}_F}{\partial\kappa}\right) = sign\left[\underbrace{\left(\frac{\partial\hat{N}_F}{\partial\alpha}\right)}_{< 0} \underbrace{\left(\frac{\partial\alpha}{\partial\kappa}\right)}_{> 0} + \underbrace{\left(\frac{\partial\hat{N}_F}{\partial\kappa}\right)}_{> 0}\right]. \blacksquare$$

The ambiguity of the impact comes from the fact that the risk and ambiguity aversion coefficients have both direct and indirect impacts on the market threshold level. Figure 3 and Figure A1 in the appendix illustrates how the level of parameter α varies with risk, for different values of the ambiguity aversion parameter. Given the structural parameter of our economy i.e.

($\sigma = 0.1$, $r = 0.1$ and $\mu = 0.05$) we have $\partial\alpha/\partial\sigma < 0$ for $\kappa > 0.77^{25}$ and then, $\partial\hat{N}_F/\partial\sigma > 0$. It is also the case without ambiguity aversion, i.e. $\kappa = 0$, that $\partial\alpha/\partial\sigma < 0$ (Pennings, 2004). Figure 4 represents the market entry threshold as a function of risk. It shows that for some selected values of ambiguity aversion and in a reasonable range of value of volatility of market growth, the market entry threshold is increasing with risk. The follower is consequently better off waiting before entering the market implying a low development of new varieties. Figure 5 represents market entry threshold as a function of ambiguity aversion for the economy with $\sigma = 0.1$, $r = 0.1$ and $\mu = 0.05$. The market entry threshold is decreasing in ambiguity aversion until $\kappa < 0.491$ and increasing thereafter. Given the other parameters of the model, we can show numerically that the follower's market entry threshold is strictly increasing in risk and ambiguity aversion for $\sigma > 0.037$ and $\kappa > 1.131$.

The follower's optimal quality given the value of the leader's quality is:

$$s_F = \frac{2(\alpha - 1)}{\alpha - 2} s_L \quad (27)$$

From equation (27) it follows that the degree of differentiation between the two firms is a function of risk and ambiguity aversion.

Proposition 3 *An increase in risk ($\sigma \uparrow$) has an ambiguous impact on the degree of differentiation while an increase in ambiguity aversion ($\kappa \uparrow$) decreases the degree of differentiation between the two competing firms.*

Proof. The first part holds because $sign[\partial(s_F/s_L)/\partial\sigma] = sign\left[\underbrace{(\partial(s_F/s_L)/\partial\alpha)}_{< 0} \underbrace{(\partial\alpha/\partial\sigma)}_{\leq 0}\right]$.

The second part follows from $sign[\partial(s_F/s_L)/\partial\kappa] = sign\left[\underbrace{(\partial(s_F/s_L)/\partial\alpha)}_{< 0} \underbrace{(\partial\alpha/\partial\kappa)}_{> 0}\right] < 0$. ■

Figure 6 shows that given the value of ambiguity aversion, there a risk level threshold at which product differentiation starts to increase with the risk level. In a case of multi-product firms, Carlton and James Jr. (2008) find that demand uncertainty and sunk costs increase product variety and firm differentiation, which may soften competition and lead to higher prices. Pennings (2004), Pawlina and Kort (2010) and Santiago (2011) also find that the level of differentiation between products is increasing with the level of risk. Product differentiation is strictly decreasing with the level of ambiguity aversion, indicating a lower likelihood of the follower's investing in quality.

²⁵Barham et al. (2012) conduct experiments measuring risk and uncertainty aversion of USA farmers. The authors get a mean of 0.79 for the uncertainty aversion with a standard deviation of 0.64.

If we plug equations (26) and (27) in the follower's profit function, the follower's expected profit is:

$$\pi_F = \frac{4(\alpha - 1)}{(\alpha - 2)^2} \left(\frac{M(2 - \alpha)}{9(r - (\mu - \sigma\kappa))(1 - \alpha)} \right)^\alpha \bar{h}^{1-\alpha} s_L^{2-\alpha} \quad (28)$$

Corrolary 1 *An increase in risk ($\sigma \uparrow$) has an ambiguous impact on the follower's profit, while an increase in ambiguity aversion ($\kappa \uparrow$) decreases the follower's profit.*

Proof. The result comes from proposition 3 and the follower's profit function. ■

Chevalier-Roignant et al. (2011, p 646) also note the ambiguity of the overall net effect of risk. Figure 7a-7b illustrates the ratio of the follower's profit when providing a high-quality good (π_{h_q}) to its profit when it provides a low-quality good (π_{l_q}) as a function of the leader's level of quality (s_L) and respectively for $\sigma = 0.05$, $\sigma = 0.10$ and $\sigma = 0.15$. The figures show that it is better for the follower to provide a lower-quality good when market development is perceived to be risky ($\pi_{h_q}/\pi_{l_q} < 1$). In that case, the equilibrium outcome will be the follower's providing lower quality and the leader higher quality. The Stackelberg profit functions are convex, which favor overinvestment with volatility. However, the overall expected gain from the investment depends on the magnitude of the advantages from the investment in quality, which is reduced when the leader provides a high-quality good. Providing such a good is associated with waiting before entering the market. Without ambiguity aversion, Pennings (2004) also shows that, for the highest level of risk, the follower's profit converges to the profit when it provides a lower-quality good. The impact of ambiguity aversion ($\kappa \uparrow$) is less clear for the low level of quality choice by the leader, as can be seen in Figure 8. Nonetheless, the follower is better off providing low quality when the market appears ambiguous *and* the quality of the leader's product is high. Waiting to provide a higher-quality good does not compensate for the loss of revenue from not entering the market. Under risk and ambiguity aversion, equilibrium outcome converges to the follower's supplying low-quality goods. As in Pennings (2004), risk increases the market threshold optimal value, at which time the leader can earn monopoly profits. Extending Aoki and Prusa's (1997) results, Pennings (2004) also shows that when the risk is below a certain level, the follower enters the market very early, and the period of the monopoly profit is not long enough to compensate for the disadvantage of supplying a low-quality good.

5 Optimal quality with vertically integrated buyers

Let us now assume that the buyers and producers are integrated with those of the suppliers, where the suppliers own all the assets.²⁶ More specifically, we assume that buyers *backward* integrate by purchasing the assets of downstream producers (Acemoglu et al., 2010).²⁷

Given the supplier's profit function, defined by equations (4)-(6), the profit of the *backward vertically integrated* (VI) buyers are now:

$$\pi_L^{VI} = \left(\frac{M}{N_L}\right)^\alpha \left[\frac{M(p_L - c(s_L) - c)q_L}{(r - (\mu - \sigma\kappa))} - I(s_L) \right] \quad (29)$$

$$\pi_F^{VI} = \left(\frac{M}{N_F}\right)^\alpha \left[\frac{M(p_F - c(s_F) - c)q_F}{(r - (\mu - \sigma\kappa))} - I(s_F) \right] \quad (30)$$

5.1 Stackelberg-Nash game with the integrated follower supplying a lower-quality good

When the follower provides a lower-quality good, it chooses the minimum quality and enters the market immediately, as does the leader.

With the cost function defined by equation (5), the quality supplied by the leader is now:

$$s_L^{VI} = \frac{9\hbar(r - (\mu - \sigma\kappa)) + 4M\lambda_L + \Delta}{3M\lambda_L^2} \quad (31)$$

where $\Delta \equiv \sqrt{81((r - (\mu - \sigma\kappa)))^2 \hbar^2 + 4M\lambda_L(18(r - (\mu - \sigma\kappa))\hbar + M\lambda_L)}$. The next proposition presents the leader's optimal choice of quality under vertical integration (VI) and non-integration (NI).

Proposition 4 *Without vertical integration, the leader underprovides quality if its cost function parameter is high and overprovides quality if its cost function parameter is low. When the leader overprovides quality, an increase in risk ($\sigma \uparrow$) and in ambiguity aversion ($\kappa \uparrow$) induces*

²⁶Three main reasons could explain the relationship between vertical integration and innovation (Armour and Teece, 1980). Firstly, vertical integration circumvents the problem of holdup. Secondly, vertical integration can facilitate the implementation of an innovation. Thirdly, vertical integration may facilitate better the alignment of objectives between the various stages.

²⁷As mentioned by Karantininis, Sauer and Furtan (2010), while the transaction cost arguments do not distinguish between the forms of integration, incomplete contract theory allows for the distinction between forward and backward integration. Specifically, *backward vertical integration* gives greater investment incentives to the producer (downstream), while *forward vertical integration* encourages supplier investment (upstream).

(i) an increase in the difference in product differentiation between vertically integrated and non-integrated buyers and (ii) a decrease of the .

Proof. The first part of proposition 4 follows the fact that, given equations (22) and (31), $\widehat{s}_L^{VI} - \widehat{s}_L^{NI} > 0$ for $\lambda_L < \frac{12(r-(\mu-\sigma\kappa))h}{M}$. It is straightforward to derive that, given (22) and (31) we have that $\partial(\widehat{s}_L^{VI} - \widehat{s}_L^{NI})/\partial\sigma > 0$ and $\partial(\widehat{s}_L^{VI} - \widehat{s}_L^{NI})/\partial\kappa > 0$. ■

Vertical integration brings the leader near the optimal level of quality from which it deviated because of risk and uncertainty. Without risk and ambiguity aversion, Economides (1999) finds that the integrated monopolist provides a higher-quality product than the non-integrated monopolist. Acemoglu et al. (2009) obtain the same result (main effect) in an imperfect credit market. Recently, Karantininis, Sauer and Furtan (2010) show empirically that vertical integration is associated with higher levels of product innovation by firms.²⁸

Corrolary 2 *When the leader provides a high-quality good, vertical integration is more likely when the economic environment is characterized by risk and ambiguity aversion.*

Proof. Profit functions are increasing in product differentiation. Under vertical integration, when risk and ambiguity is high, the leader provides a higher-quality good and thus increases both its profit and that of the follower (higher prices and demand). ■

Given equations (22) and (31), our results show that threshold level of the cost parameter for over providing quality is increasing in risk as well as in ambiguity aversion. When the economic environment is characterized by risk and ambiguity aversion and the leader provides a high-quality good, vertical integration is more likely because of the increase in the quality of the product as well as in the threshold level of the cost parameter under which it overprovides quality. Lafontaine and Slade's (2007) review the findings of empirical studies on vertical integration and firms boundaries. The authors show that, whenever its effect is significant, higher uncertainty of the upstream market leads to more *backward* vertical integration which is consistent with the transaction-cost economics. Our results show that when the cost parameter is high the impact of the risk in determining tendency toward *backward* vertical integration will be negative.²⁹

²⁸Karantininis et al. (2010) also show that *forward* vertical integration as well as *backward* vertical integration tend to increase agri-food product innovation.

²⁹Lafontaine and Slade (2007) also report a negative tendency of risk on the incentive to vertically integrate. But the effect is not significant. In addition in most of the studies on *forward* integration and contrary to predictions, increased risk is associated with less integration.

5.2 Stackelberg-Nash game with the follower supplying a higher-quality good

Because the explicit solution of the first order condition is highly complex, we rely on numerical simulations, using the parameters defined in Section 3.4. As for the case when the leader supplies a high quality good, vertical integration increases the quality level of the supplied good. Both ambiguity aversion and volatility risk increase the length of the difference between the quality supplied by the VI and the NI buyers. If the leader provides a lower-quality good the gain in the follower's delaying entry is a function of the model parameters. However, vertical integration reduces the waiting time, and the follower enters the market earlier than it would in the absence of vertically integration if $\frac{1}{4(s_F - s_L)} > \frac{(s_F - s_L)}{[s_F(\lambda_F s_F - 2) - s_L(\lambda_L s_L - 2)]^2}$ implying that the follower enters earlier for $s_F(\lambda_F s_F - 2) - s_L(\lambda_L s_L - 2) > 2$. Let us assume that $\lambda_L = \lambda_F = \lambda$. Under vertical integration the follower enters earlier whenever $s_F(\lambda s_F - 2) - s_L(\lambda s_L - 2) > 2$, which is reached for the quality $s_F > \frac{1 + \sqrt{1 + 2\lambda(1 - s_L) + \lambda^2 s_L^2}}{\lambda}$. If the leader chooses the lowest quality possible $s_L = \underline{s} = 0$, the condition is $s_F > \frac{1 + \sqrt{1 + 2\lambda}}{\lambda}$. Figure 9 represents the choice of quality when the follower provides a higher-quality good and under different value of cost parameter. Risk and ambiguity aversion impact the level of quality of the VI buyer and indirectly reduce waiting time. Overall vertical integration is welfare improving because, for a given level of risk and ambiguity aversion, it increases the quality of the product supplied by the follower and reduces the waiting time. Non-integration and the presence of risk and/or ambiguity aversion could explain why, in some cases, leaders in the agri-food sector are rather slow to introduce high-quality products.³⁰

6 Conclusion

This paper analyzes the impact of risk and Knightian uncertainty on the choice of optimal quality and the timing of market entry. Irreversibility of the investment in product development is introduced in a continuous-time stochastic model applying the real option literature. We consider a market characterized by a duopoly with a Stackelberg-Nash game for quality choice, within a framework of non-integrated and vertically integrated firms. Our results show that up to certain threshold levels, risk and ambiguity aversion reduce the optimal quality level and increase the value of delaying entry when the follower supplies the higher-quality good. The implication is that under high levels of risk and under ambiguity aversion the model predicts a sustained monopoly profit for the leader. Vertical integration reduces the follower's value of waiting and increases its optimal quality; hence both competition and welfare increase. We also show that the difference between the entry delay of vertically integrated and non-integrated

³⁰ Also see Moretto (2008)

firms is increasing in risk and uncertainty aversion. Vertical integration tends to correct the underinvestment in quality because of risk and ambiguity aversion. When the economic environment is characterized by risk and ambiguity aversion and the leader provides a high-quality good, vertical integration is more likely because of the increase in the quality of the product as well as in the threshold level of the cost parameter under which it overprovides quality. When the follower supplies the lower-quality good there is no value to waiting, and it is better off providing the lowest quality possible. When the follower provides a higher-quality good, the level of quality is decreasing in ambiguity aversion while it is a non-monotonic function of the level of risk. Vertical integration increases the leader's optimal choices of quality and the market entry threshold.

Overall, our results show that the impacts of risk and Knightian uncertainty on the optimal quality are different. As pointed out by Miao and Wang (2011) and Asano and Shibata (2011) making the distinction between risk and ambiguity aversion is important. In agri-food supply chains risk and ambiguity about the growth of the market can be explained by several factors including consumers' concerns about product quality and safety, macroeconomic and agricultural policies, sanitary crises and natural disasters. Furthermore, the level of ambiguity aversion is likely to vary. Further empirical research is needed to disentangle the effect of ambiguity aversion from those of risk implying to account for partial identification and thereby ambiguity that does not vanish with sample size (see Bewley, 2011; Stoye, 2012). Our results also show that contract farming and vertical integration observed in the food industry seems to be an adequate response to the need of innovations under risk and ambiguity aversion. The hog supply chain of Quebec experiences *backward* and *forward vertical integration* and while the transaction cost arguments do not distinguish between the forms of integration, incomplete contract theory allows for the distinction between them. We show that when the economic environment is characterized by risk and ambiguity aversion, *backward* vertical integration observed in the food industry seems to be an adequate response to the need of innovations. It would be interesting, to know how, under incomplete information between the agents (producers and buyers), innovation decisions are affected by the risk and ambiguity aversion.

References

- Aoki, R. and T.J. Prusa.** 1997. Sequential versus simultaneous choice with endogenous quality. *International Journal of Industrial Organization* 15, 103-121.
- Acemoglu, D.; P. Aghion; R. Griffith and F. Zilibotti.** 2010. Vertical integration and technology: theory and evidence. *Journal of the European Economic Association*, 8, 989-1033.
- Acemoglu, D., S. Johnson and T. Mitton.** 2009. Determinants of vertical integration: financial development and contracting cost. *The Journal of Finance*, LXIV, 1251-1290
- Armour, H.O. and D.J. Teece.** 1980. Vertical integration and technological innovation. *The Review of Economics and Statistics* 62 (3), 470-474.
- Asano, T. and A. Shibata.** 2011. Optimal pricing and quality choice of a monopolist under Knightian uncertainty. *International Journal of Industrial Organization* 29, 746-754.
- Bergemann, D. and J. Välimäki.** 2002. Entry and vertical differentiation. *Journal of Economic Theory* 106, 91-125.
- Bergès, F. and Z. Bouamra-Mechemache.** 2012. Is producing private label counterproductive for a branded manufacturer? *European Review of Agricultural Economics* 39, 213-239.
- Bewley, T.F.** 2002. Knightian decision theory: Part I decision in economics. *Finance* 25. 70-110.
- Bewley, T.F.** 1989. Marketing innovation and entrepreneurship: A Knightian view. *Discussion paper, Cowles Foundations*.
- Bewley, T.F.** 2011. Knightian decision theory and econometric inferences. *Journal of Economic Theory* 146, 1134-1147
- Barham, B. L., J-P. Chavas, D. Fitz, V. Rios Salas and L. Schechter.** 2012. The Roles of Risk and Ambiguity in Technology Adoption. Unpublished paper. Available at SSRN: <http://ssrn.com/abstract=1937849> or <http://dx.doi.org/10.2139/ssrn.1937849>.
- Boehlje, M, M. Roucan-Kaneb and S. Bröring.** 2011. Future Agribusiness Challenges: Strategic Uncertainty, Innovation and Structural Change. *International Food and Agribusiness Management Review*, Volume 14, Issue 5.
- Carlton, D.W. and D.D. James Jr.** 2008. Product variety and demand uncertainty: Why markups vary with quality. *Journal of Industrial Economics* 56, 535-552
- Chen, Z. and L. Epstein.** 2002. Ambiguity, risk and asset return in continuous time. *Econometrica* 70, 1403-1443.
- Chevalier-Roignant, B, C.M. Flath, A. Huchzermeier and L. Trigeorgis.** 2011. Strategic investment under uncertainty: a synthesis. *European Journal of Operational Research* 215, 639-650.
- De Castro, L.I. and A. Chateauneuf.** 2011. Ambiguity aversion and trade. *Economic Theory* 48, 243-273.

- Dixit, A.K. and R.S. Pindyck.** 1994. Investment under uncertainty. Princeton University Press, Princeton, New Jersey.
- Economides, N.** 1999. Quality choice and vertical integration. *International Journal of Industrial Organization* 17, 903-914.
- Ellsberg, D.,** 1961. Risk, ambiguity, and the savage axioms. *Quarterly Journal of Economics* 75, 643–669.
- Engle-Warnick, J., J. Escobal, and S.Laszlo.** 2011. Ambiguity aversion and portfolio choice in small-scale Peruvian farming. *B.E. Journal of Economic Analysis and Policy* 1: 68p.
- Gervais, J-P. and R. Lambert.** 2010. The simple economics of hog marketing reforms in Québec. SPAA Network Working paper, 2010-01.
- Ghazalian, P.L.** 2012. Home Bias in Primary Agricultural and Processed Food Trade: Assessing the Effects of National Degree of Uncertainty Aversion. *Journal of Agricultural Economics* 63, 265-290.
- Gilboa, L.** 2009. Theory of decision under uncertainty. Cambridge University Press.
- Häckner, J. A** 2000. Note on price and quantity competition in differentiated oligopolies, *Journal of Economic Theory* 93, 233-239.
- Handley, K. and N. Limão.** 2012. Trade and investment under policy uncertainty: Theory and Firm Evidence. NBER Working Paper No. 17790.
- Hofstede, G.H.,** 1980. Culture's consequences: International differences in work-related values. Sage, Thousand Oaks, CA.
- Hofstede, G.H.,** 2001. Culture's consequences: Comparing values, behaviors, institutions, and organizations across nations. Sage, Thousand Oaks, CA.
- Huang, R.R.,** 2008. Tolerance of uncertainty and the growth of informationally opaque industries. *Journal of Development Economics* 87, 333–353
- Huang, R.R.** 2007. Distance and Trade: Disentangling unfamiliarity effects and transport cost effects. *European Economic Review* 51, 161-181.
- James Jr, H.S., M.K. Hendrickson and P.H. Howard.** 2012. Networks, Power and Dependency in the Agrifood Industry. Department of Agricultural & Applied Economics Working Paper . Available at SSRN: <http://dx.doi.org/10.2139/ssrn.2004496>
- James Jr, H.S., P.G. Klein and M.E. Sykuta.** 2011. The adoption, diffusion and evolution of organizational form: insight from the agrifood sector. *Managerial and Decision Economics* 32: 243-259.
- Karantininis, K., J. Sauer and W.H. Furtan.** 2010. Innovation and integration in the agri-food industry. *Food Policy* 35, 112–120.
- Kong, J.J. and Y.K. Kwok.** 2007. Real option in strategic investment game between two asymmetric firms. *European Journal of Operational Research* 181, 967-985.

- Lafontaine, F and M. Slade.** 2007. Vertical integration and firm boundaries: the evidence. *Journal of Economic Literature* XLV, 629-685.
- Lavoie, N.** 2005. Price Discrimination in the Context of Vertical Differentiation: An Application to Canadian Wheat Exports. *American Journal of Agricultural Economics* 87: 835-854.
- Lopez, R.A., A.M. Azzam and C. Liron-Espana.** 2002. Market power and/or efficiency: A structural approach. *Review of Industrial Organization* 20, 115-126.
- Maggi, G.** (1999). The Value of commitment with imperfect observability and private information. *Rand Journal of Economics* 30, 555-574.
- MAPAQ** [Ministère de l'Agriculture, de l'Alimentation et des Pêcheries du Québec]. 2010. Monographie de l'industrie porcine québécoise. Available at http://www.mapaq.gouv.qc.ca/fr/Publications/monographieporc_finale%282%29.pdf. Accessed May 9, 2012.
- Miao, J. and N. Wang.** 2011. Risk, uncertainty, and option exercise. *Journal of Economic Dynamics and Control* 35, 442-461.
- Möhlmann, L.J.; S. Ederveen; H.L.F de Groot and G-J M Linders.** 2010. Intangible barriers to international trade. A Sectoral approach. In Gravity Model in International Trade. Advances and Applications. P.A.G. van Bergeijk and S. Brakman eds. 224-251.
- Moreto, M.** 2008. Competition and irreversible investments under uncertainty. *Information Economics and Policy* 20, 75-88.
- Mussa, M. and S. Rosen.** 1978. Monopoly and product quality. *Journal of Economic Theory* 18, 301-317.
- Nishimura, K.G. and H. Ozaki.** 2007. Irreversible investment and Knightian uncertainty. *Journal of Economic Theory* 136, 668 – 694.
- Pawlina, G. and P.M. Kort.** 2010. Strategic quality choice under uncertainty: a real option approach. *The Manchester School* 78, 1-19.
- Pennings, E.** 2004. Optimal pricing and quality choice when investment in quality is irreversible. *Journal of Industrial Economics* 52, 569-589.
- Rigotti, L. and C. Shannon.** 2005. Uncertainty and risk in financial market. *Econometrica* 73, 203-243.
- Sadanand, A. and V. Sadanand.** 1996, Firm scale and endogenous timing of entry: a choice between commitment and Flexibility, *Journal of Economic Theory* 70, 516–530.
- Santiago, B.** 2011. Product differentiation and systematic risk: theory and empirical evidence. Unpublished paper.
- Scherer, F.,** 1980, Industrial market structure and economic Performance Chicago: Rand McNally.
- Shaked, A. and J. Sutton.** 1982. Relaxing price competition through product differentiation. *Review of Economic Studies* 49, 3-13.

Sheldon, I.M. and B.E. Roe 2009. Public vs private eco-labelling of environmental credence goods: maximizing the gains from international integration. *Journal of Agricultural Food Industrial Organization* 7, Article 4.

Spence, M. 1975. Monopoly, quality and regulation. *Bell Journal of Economics* 6, 417-429.

Stiegert, K.W., S.S. Wang and R.T.Rogers. 2009. Structural Change and Market Power in the U.S. Food Manufacturing Sector. *Agribusiness* 25, 164-180.

Stoye, J. 2012. New Perspectives on Statistical Decisions Under Ambiguity. *Annual Review of Economics* 4:1.1–, 1.26.

Uppal, R. and T. Wang. 2003. Model misspecification and under diversification. *Journal of Finance* 48, 2465–2486.

Wang, Z. 2010. Irreversible investment of the risk- and uncertainty averse DM under k-ignorance: the role of BSDE. *Annals of Economics and Finance* 11, 313-335.

Weeds, H. 2002. Strategic delay in real option model of R&D competition. *Review of Economic Studies* 69,729-747.

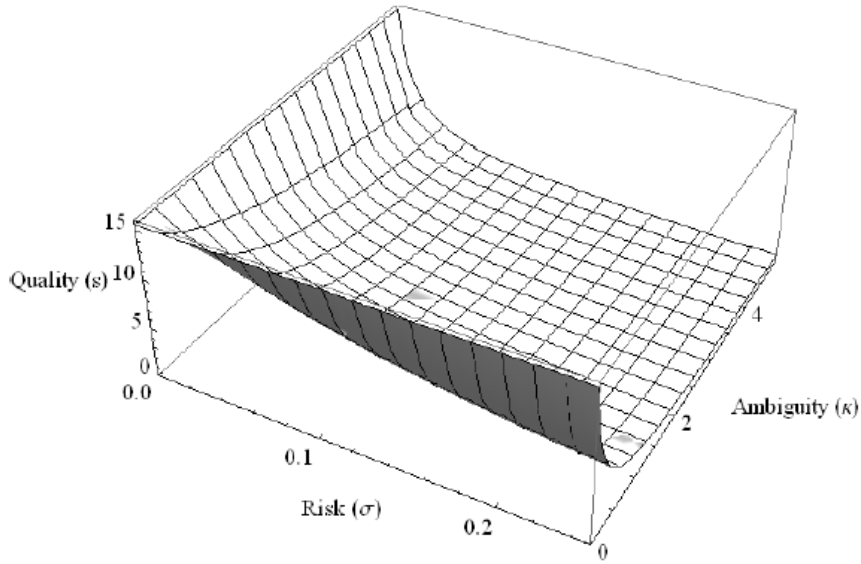

Figure 1. Leader's choice of quality as a function of risk (σ) and uncertainty aversion (κ) when the leader provides a higher-quality good

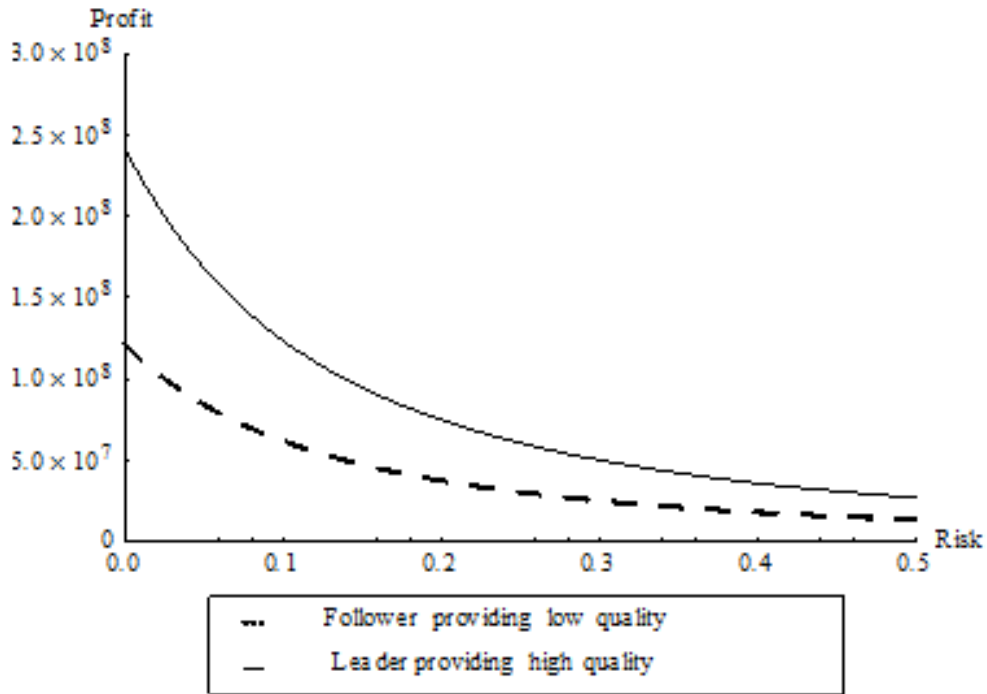

Figure 2a. Equilibrium profits of the two firms as a function of risk (σ) when the leader provides a higher-quality good with $\kappa = 0.2$

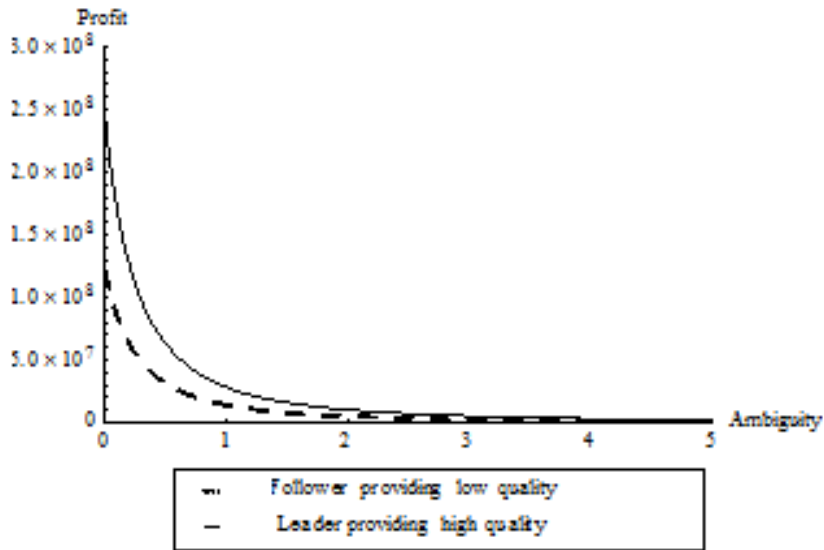

Figure 2b. Equilibrium profits of the two firms as a function of uncertainty aversion (κ) when the leader provides a higher-quality good with $\sigma = 0.1$

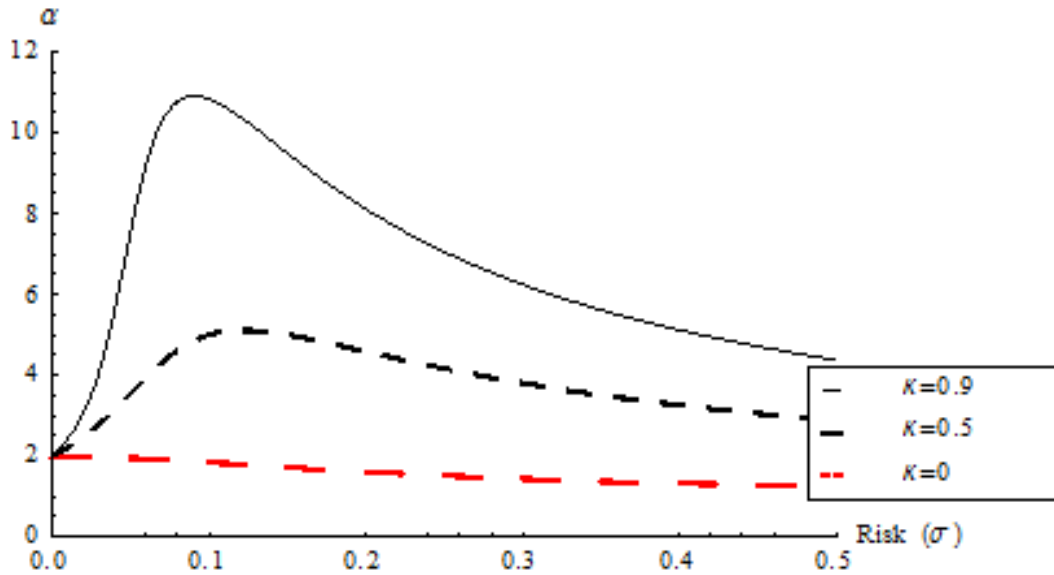

Figure 3. Impact of risk (σ) on the value of parameter α given certain value of uncertainty aversion parameter κ

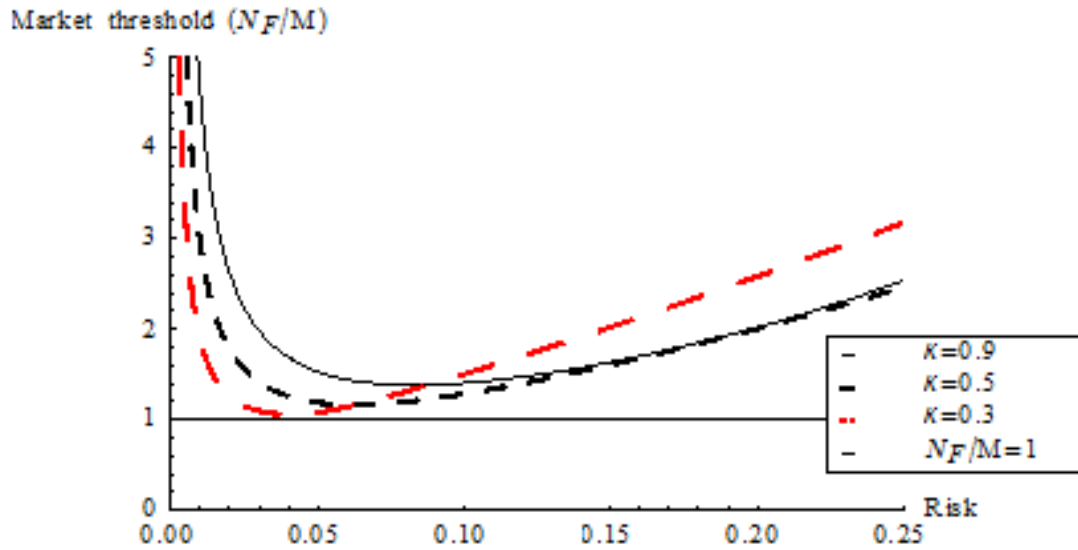

Figure 4. Market entry threshold (as a portion of the market) as a function of risk with $r = 0.1$, $\mu = 0.05$

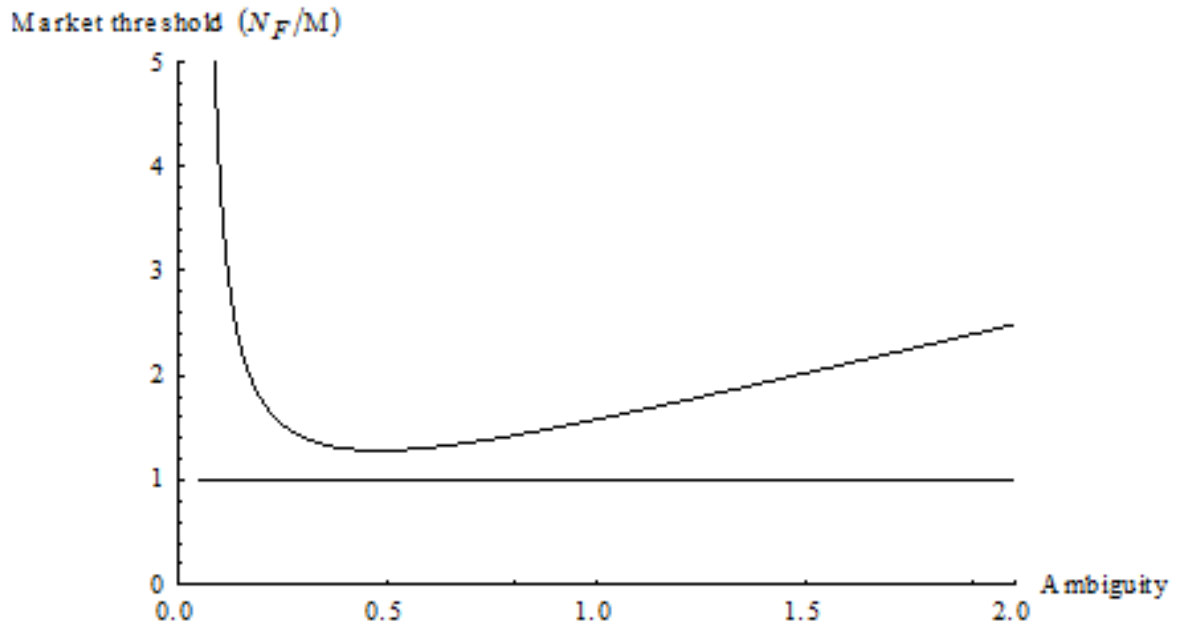

Figure 5. Market entry threshold as a function of uncertainty aversion with $\sigma = 0.1$, $r = 0.1$, $\mu = 0.05$

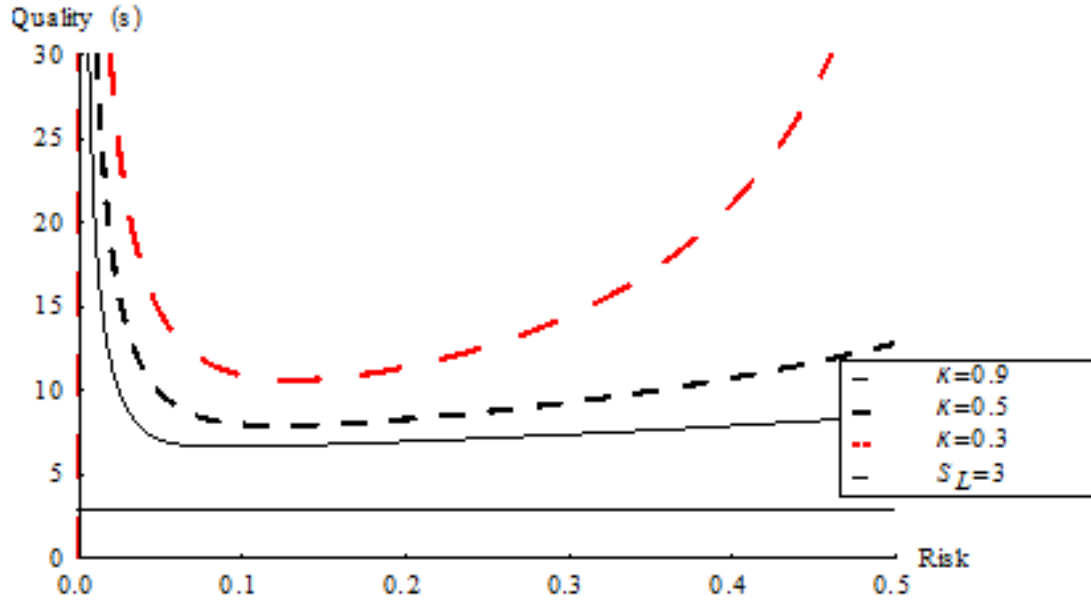

Figure 6. Follower’s choice of quality as a function of risk (σ) when the follower provides a high quality

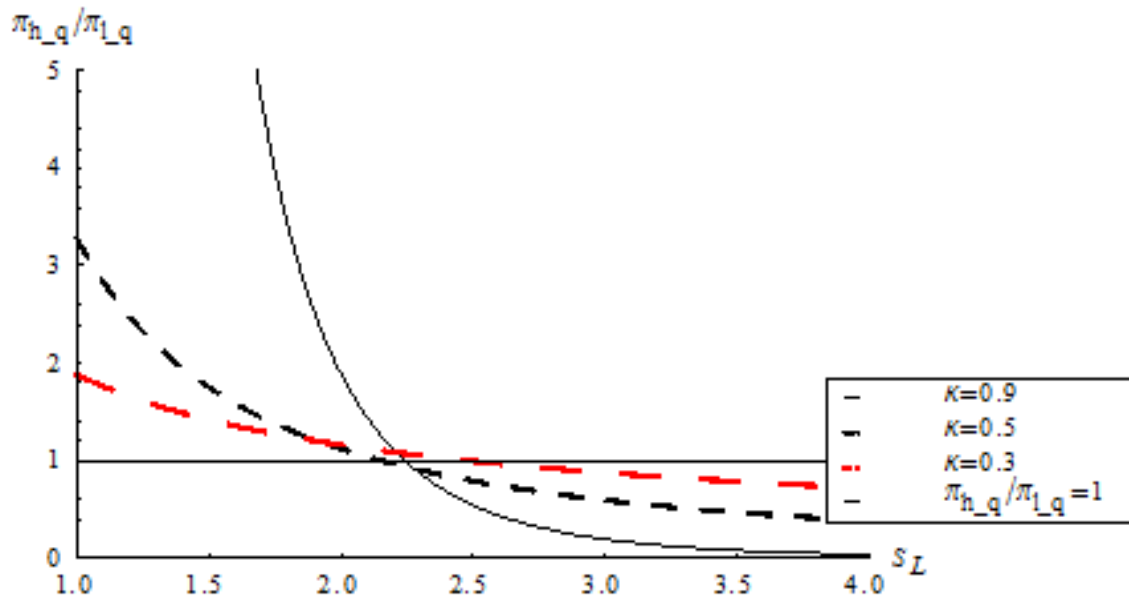

Figure 7a. Follower outcome as a function of quality provided by the leader, given values of uncertainty aversion κ and $\sigma = 0.05$

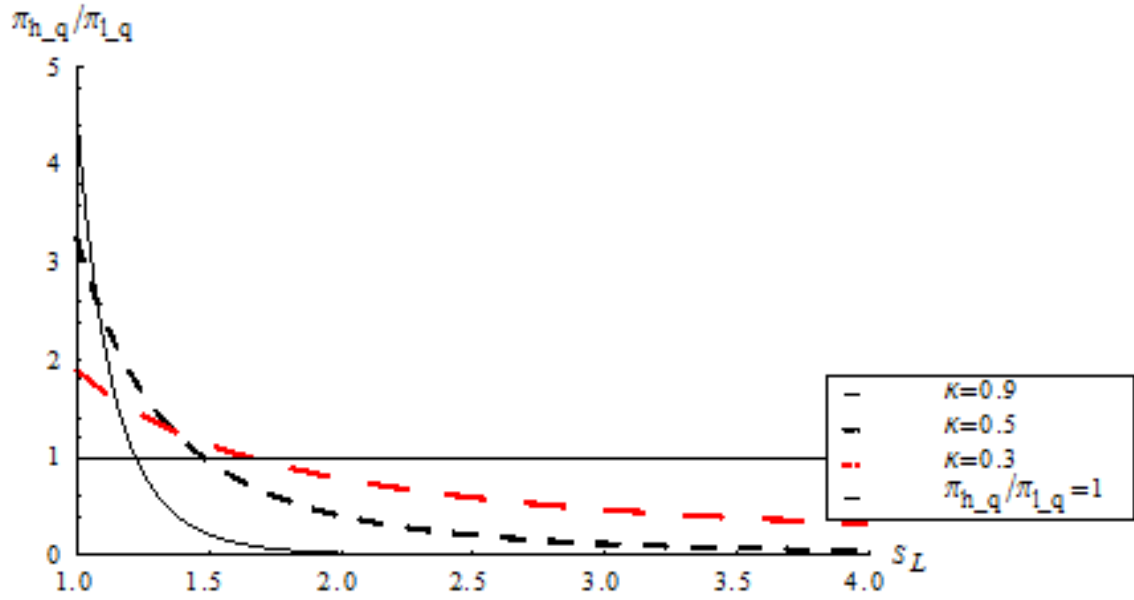

Figure 7b. Follower outcome as a function of quality provided by the leader, given values of uncertainty aversion κ and $\sigma = 0.15$

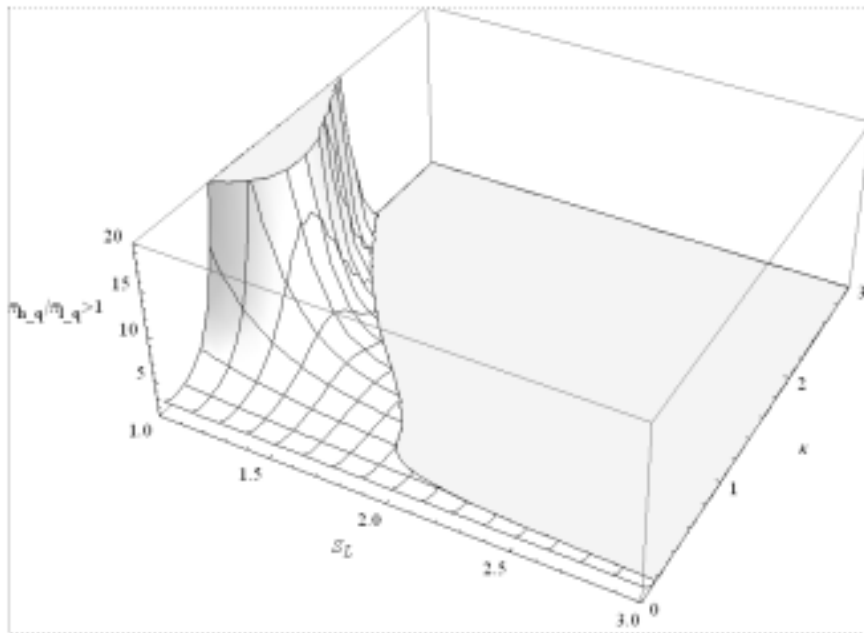

Figure 8. Follower outcome as a function of quality provided by the leader, given values of uncertainty aversion κ and $\sigma = 0.1$

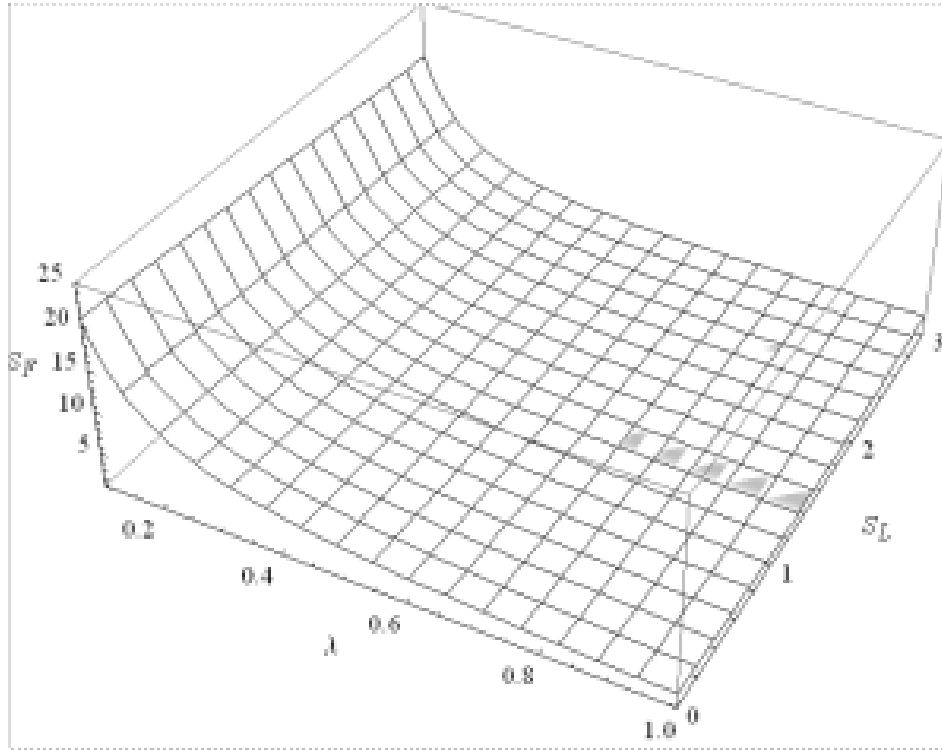

Figure 9. Follower choice of quality when entering earlier in the market

Appendix

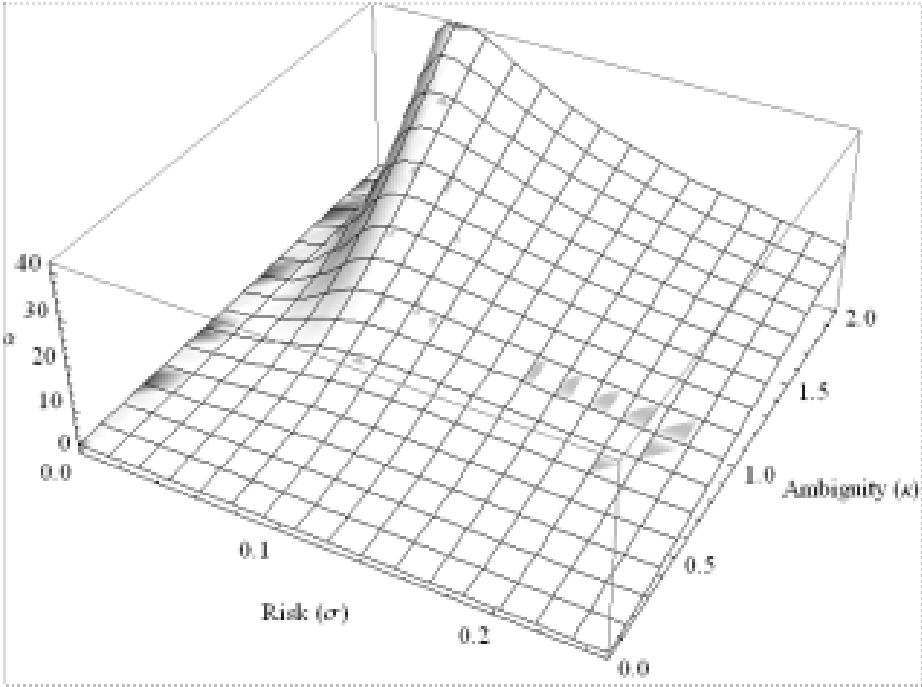

Figure A1. Impact of risk (σ) and uncertainty aversion (κ) on the value of the parameter α